

Copyright © 1998 Nokia Mobile Phones. All rights reserved.
 Unauthorized reproduction of this drawing is not permitted.

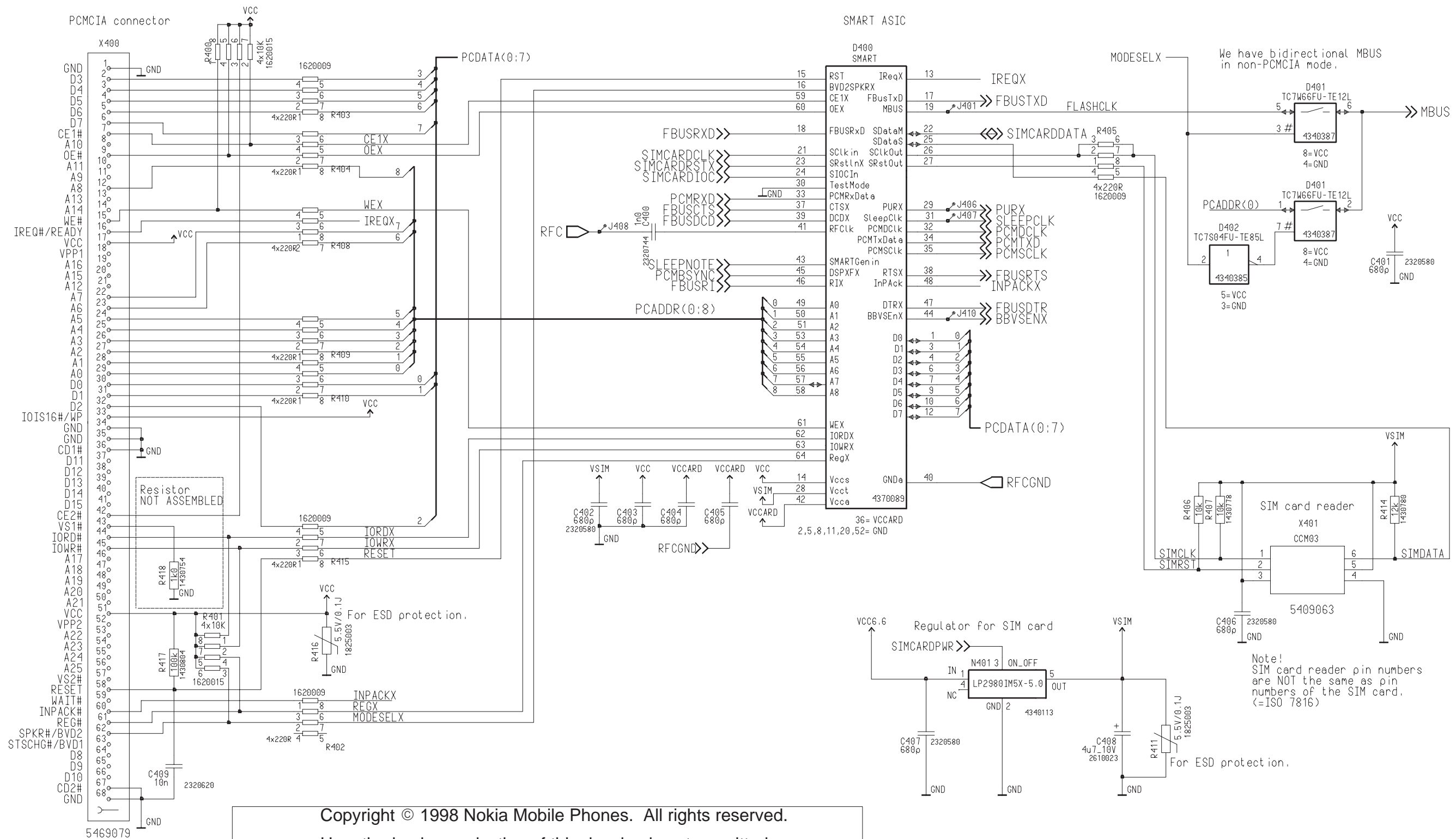

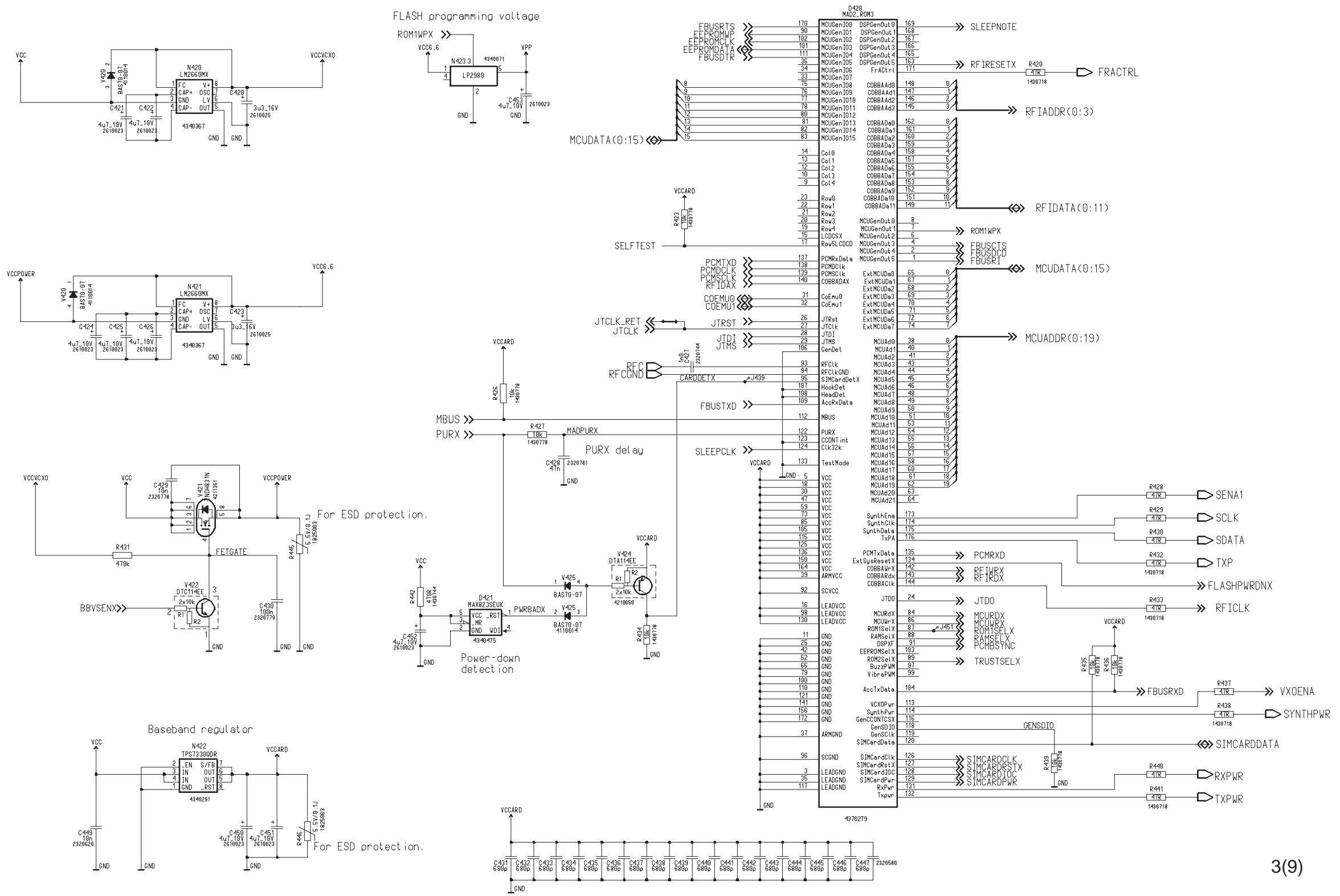

Copyright © 1998 Nokia Mobile Phones. All rights reserved.
 Unauthorized reproduction of this drawing is not permitted.



Copyright © 1998 Nokia Mobile Phones. All rights reserved.
 Unauthorized reproduction of this drawing is not permitted.

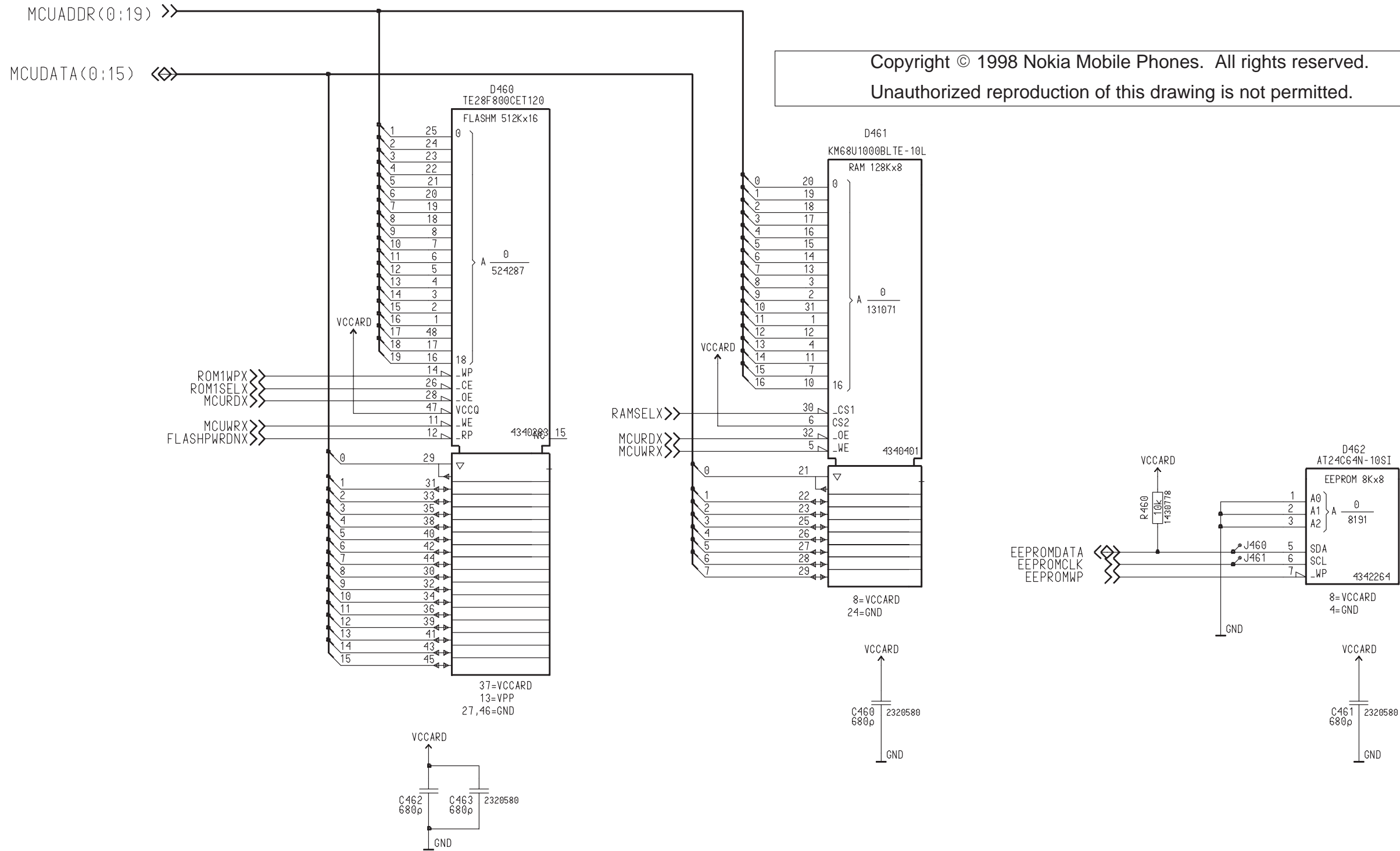

Circuit Diagram of RFI (Version 2.97 Edit 10) for layout version 18

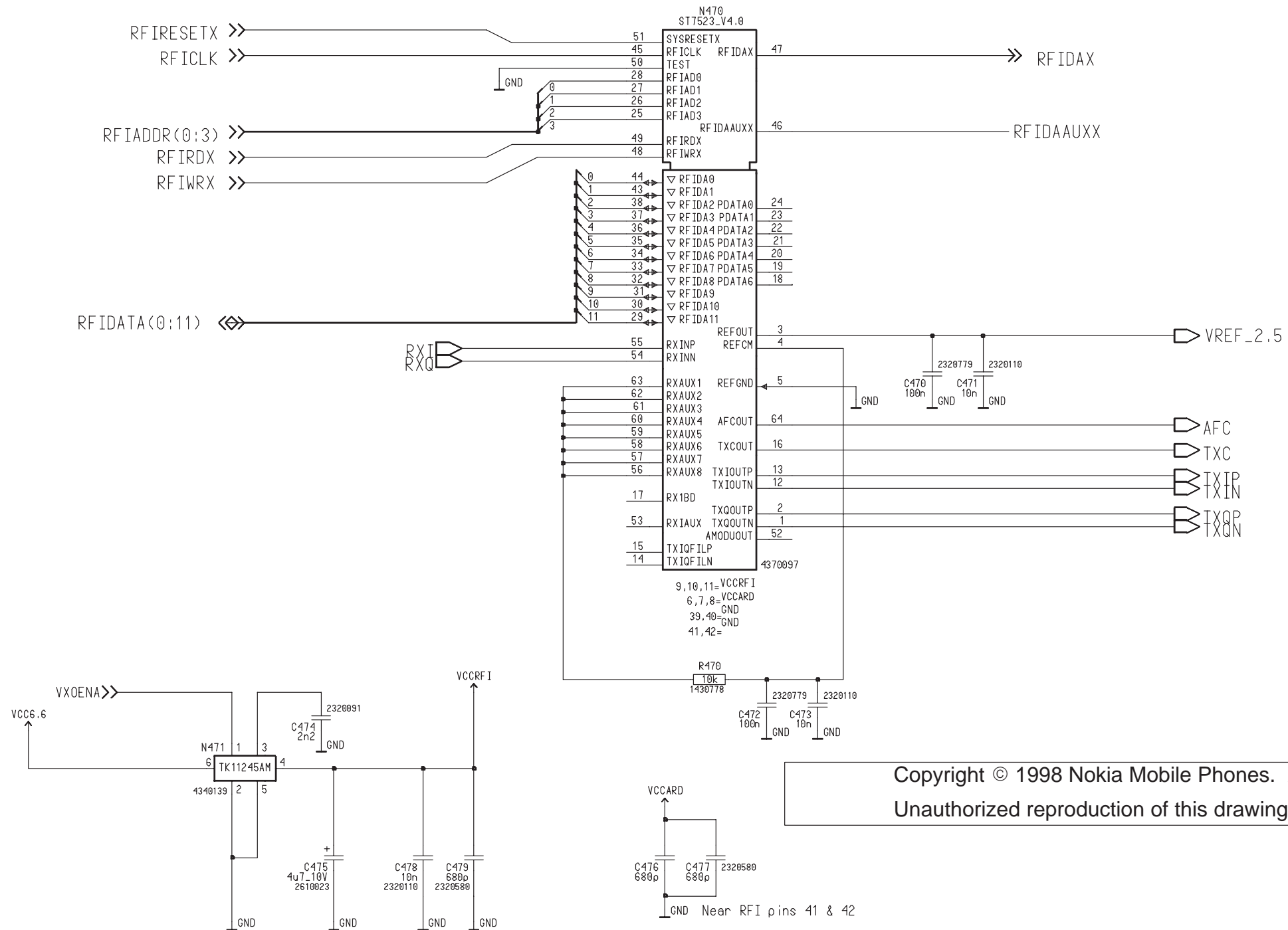

Copyright © 1998 Nokia Mobile Phones. All rights reserved.
 Unauthorized reproduction of this drawing is not permitted.

Regulator for RFI2 analog supply

Copyright © 1998
 Nokia Mobile Phones.
 All rights reserved.
 Unauthorized repro-
 duction of this drawing
 is not permitted.

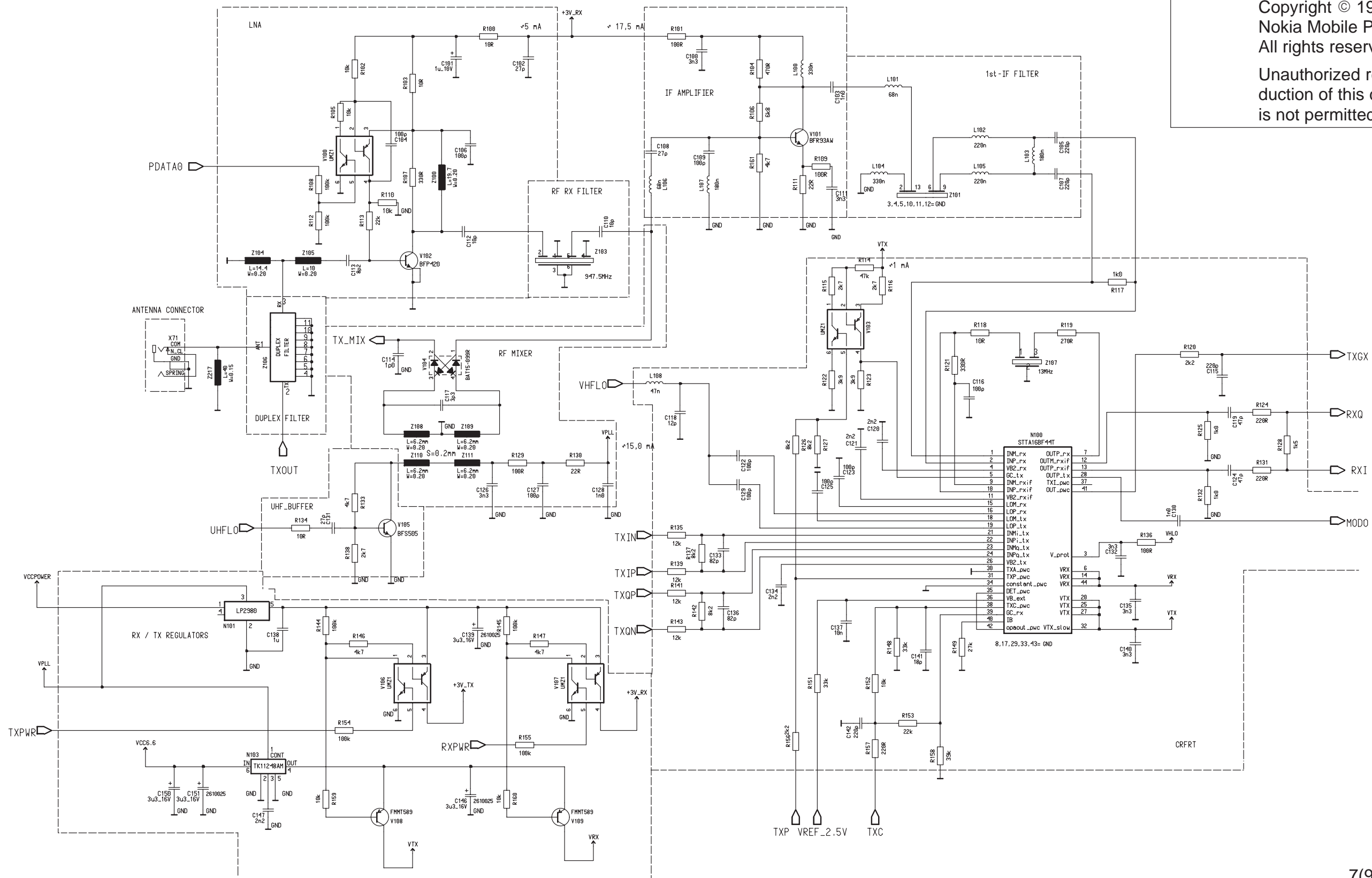

Circuit Diagram of Transmitter (Version 3.0 Edit 25) for layout version 18

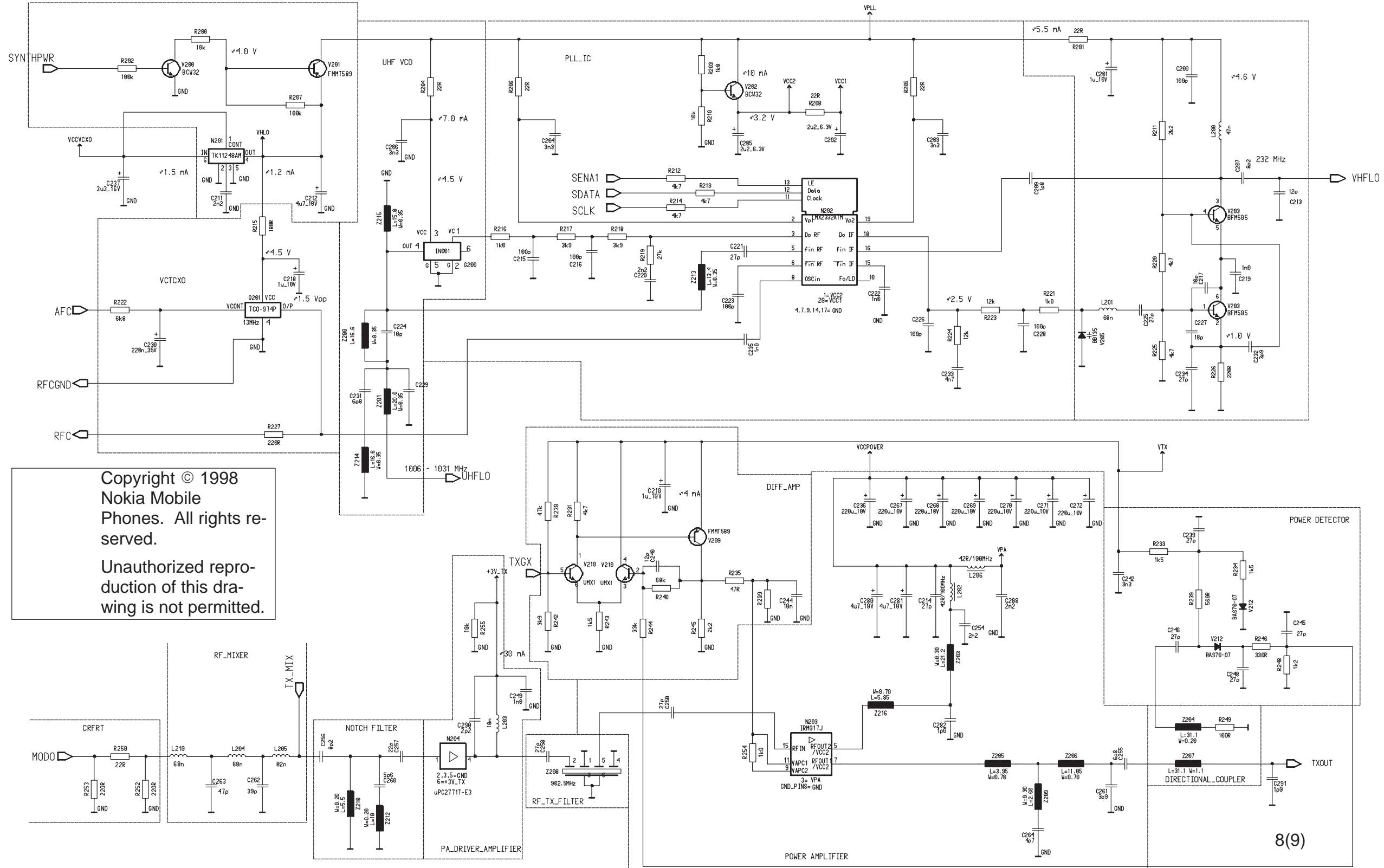

Copyright © 1998
Nokia Mobile
Phones. All rights reserved.
Unauthorized reproduction of this drawing is not permitted.



